

**Modular Cooking Range Line
 thermaline 90 - Electric Free-cooking
 Top on Warming Cabinet with
 Backsplash H=800**

ITEM # _____

MODEL # _____

NAME # _____

SIS # _____

AIA # _____

589710 (MCTHFBJ4AO)

 Electric Free-Cooking Top,
 one-side operated with
 backsplash, on Warming
 Cabinet

Short Form Specification

Item No. _____

Unit constructed according to DIN 18860_2 with 20 mm drop nose top. Internal frame for heavy duty sturdiness in stainless steel. 2 mm top in 1.4301 (AISI 304). Flat surface construction, easily cleanable. THERMODUL connection system enables seamless worktop when units are connected and avoids soil penetrating. Smooth electrically-heated solid plate made of 20 mm thick steel with a wide rounded cleaning zone around the plate. Rapid plate heat up, continuously ready to use; maximum reachable surface temperature of 350°C. Stainless steel high splash guards on the rear and sides. Overheat protection switches off the supply in case of overheating. Standby function saves energy and quickly recovers maximum power. Metal knobs with embedded hygienic silicon "soft" grip enable easier handling and cleaning. 1000 mm wide warming cabinet with 2 doors, constructed according to DIN 18860_2 with 70 mm recessed plinth. Temperature in the cabinet can be set through thermostat, up to a maximum of 110 °C. Cabinet storage space accepts GN 1/1 containers. IPX5 water resistance certification.

Main Features

- Rapid heat up of the plate and continuously ready for use.
- Overheat protection: a temperature sensor switches off the supply in case of overheating.
- Wide rounded cleaning zone around the plates for easier cleaning.
- IPX5 water resistance certification.
- All major components may be easily accessed from the front.
- THERMODUL connection system creates a seamless work top when units are connected to each other thus avoiding soil penetrating vital components and facilitating the removal of units in case of replacement or service.
- Metal knobs with embedded hygienic silicon "soft" grip for easier handling and cleaning. The special design of the controls prevent infiltration of liquids or soil into vital components.
- Large visible digital display manufactured in tempered glass to resist heat and chemicals, showing temperatures or power settings. The display also shows on/off status of the appliance and on/off status of the heating elements.
- Cooking plate and base joint profile guarantee against soil infiltration.
- Surface temperature up to 350°C
- Unit constructed according to DIN 18860_2 with 70 mm recessed plinth.
- For direct and indirect cooking.
- Temperature in the cupboard can be set through a thermostat to suit different requirements. The maximum temperature is 110°C.

Construction

- 2 mm top in 1.4301 (AISI 304).
- Unit constructed according to DIN 18860_2 with 20 mm drop nose top and 70 mm recessed plinth.
- Flat surface construction with minimal hidden areas to easily clean all surfaces
- Storage space in the base of the appliance accepts GN1/1 containers.
- Unit constructed according to DIN 18860_2 with 20 mm drop nose top.
- Cooking surface is an electrically heated solid plate made from 20 mm thick stainless steel AISI 316 - DIN 1.4404.
- 2mm thick top in stainless steel AISI 304 - DIN 1.4301.
- Internal frame for heavy duty sturdiness in stainless steel.

APPROVAL: _____

Sustainability

- Standby function for energy saving and fast recovery of maximum power.

Optional Accessories

- Connecting rail kit for appliances with backsplash, 900mm PNC 912499
- Portioning shelf, 1000mm width PNC 912528
- Portioning shelf, 1000mm width PNC 912558
- Folding shelf, 300x900mm PNC 912581
- Folding shelf, 400x900mm PNC 912582
- Fixed side shelf, 200x900mm PNC 912589
- Fixed side shelf, 300x900mm PNC 912590
- Fixed side shelf, 400x900mm PNC 912591
- Stainless steel front kicking strip, 1000mm width PNC 912600
- Stainless steel side kicking strips left and right, against the wall, 900mm width PNC 912624
- Stainless steel side kicking strips left and right, back-to-back, 1810mm width PNC 912627
- Stainless steel plinth, against wall, 1000mm width PNC 912903
- Connecting rail kit for appliances with backsplash: modular 90 (on the left) to ProThermetic tilting (on the right), ProThermetic stationary (on the left) to ProThermetic tilting (on the right) PNC 912981
- Connecting rail kit for appliances with backsplash: modular 90 (on the right) to ProThermetic tilting (on the left), ProThermetic stationary (on the right) to ProThermetic tilting (on the left) PNC 912982
- Back panel, 1000x800mm, for units with backsplash PNC 913028
- Stainless steel panel, 900x800mm, against wall, left side PNC 913102
- Stainless steel panel, 900x800mm, against wall, right side PNC 913106
- Endrail kit, flush-fitting, with backsplash, left PNC 913117
- Endrail kit, flush-fitting, with backsplash, right PNC 913118
- Scraper for smooth plates PNC 913119
- Endrail kit (12.5mm) for thermaline 90 units with backsplash, left PNC 913208
- Endrail kit (12.5mm) for thermaline 90 units with backsplash, right PNC 913209
- U-clamping rail for back-to-back installations with backsplash PNC 913226
- Insert profile d=900 PNC 913232
- Perforated shelf for warming cabinets and cupboard bases (one-side operated TL80-85-90 and two-side operated for TL80) PNC 913235
- Side reinforced panel only in combination with side shelf, for against the wall installations, left PNC 913268
- Side reinforced panel only in combination with side shelf, for against the wall installations, right PNC 913270

- Shelf fixation for TL80-85-90 one-side operated, TL80 two-side operated PNC 913283
- Filter W=1000mm PNC 913666
- Stainless steel dividing panel, 900x800mm, (it should only be used between Electrolux Professional thermaline Modular 90 and thermaline C90) PNC 913673
- Stainless steel side panel, 900x800mm, flush-fitting (it should only be used against the wall, against a niche and in between Electrolux Professional thermaline and ProThermetic appliances and external appliances - provided that these have at least the same dimensions) PNC 913689

Front

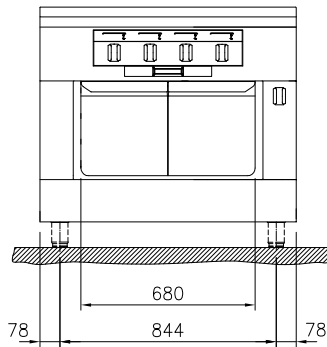

Side

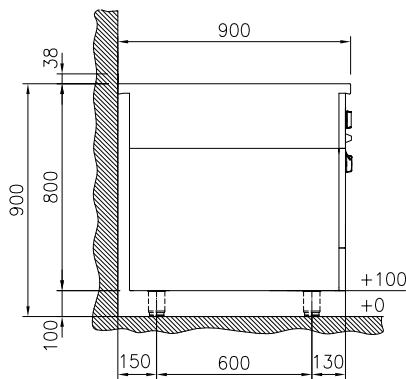

Top

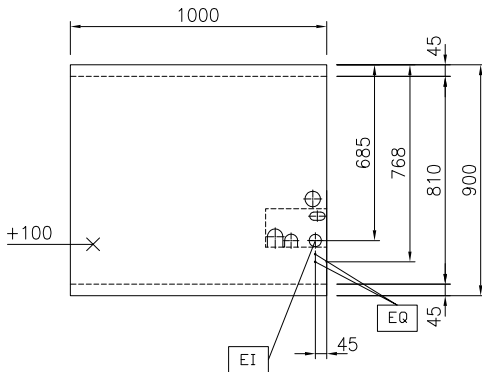

EI = Electrical inlet (power)
 EQ = Equipotential screw

Electric
Supply voltage:

589710 (MCTHFBJ4AO) 400 V/3N ph/50/60 Hz

Electrical power max.:

18.3 kW

Key Information:
Configuration: On Oven, One-Side Operated

Front Plates Power: 4 - 4 kW

Back Plates Power: 4 - 4 kW

Solid top usable surface (width): 820 mm

Solid top usable surface (depth): 720 mm

External dimensions, Width: 1000 mm

External dimensions, Depth: 900 mm

External dimensions, Height: 800 mm

Storage Cavity Dimensions (width):
Storage Cavity Dimensions (height):
Storage Cavity Dimensions (depth): 0 mm

Net weight: 258 kg

Sustainability
Current consumption: 39.1 Amps